

CycloSaver Transport Series

Oil Free Screw Compressors



GARDNER
DENVER

GD
GARDNER DENVER™

Experience Proven Results™



CycloSaver

Rotary Screw Compressor

CycloSaver machines are an innovative range of contact-less, oil free, screw type compressors designed to discharge all types of dry products from road tankers.

It's Efficient

The CycloSaver reduces horsepower consumption per cfm. CycloSaver requires up to **27% less power** to operate than other blowers, saving you valuable diesel fuel.

It's Fast

Discharge times are improved by up to 40%, allowing you to save fuel while providing a better service by maximizing your delivery windows and minimizing disruption.

"If the wheels ain't rollin', you're not earnin'!"

"Frac Sand unload time went from 1.5 hours to half an hour. (We are) extremely happy!"

—Maintenance Manager,
Canadian Trucking Company

"I have seen 20–30 minute quicker off load times."

—Operator,
Midwest Trucking Company



SAV 8 Compressor

saves you



makes you



"It's Green!"

Weight savings and you



It's Light

CycloSaver weighs as little as 257 pounds offering increased payload capacity. Compared to a typical bi-lobe blower, using a CycloSaver allows you up to 167 pounds in payload capacity per delivery.

“Based on commodity type, our annual revenue gains from weight savings alone range from \$3,000–\$5,000.”

—Purchasing Manager,
Major Fleet Hauler

It's Flexible

The pressure and flow ranges produced by the CycloSaver allow all dry bulk solids to be discharged at optimum flow rates.

Designed exclusively for off loading dry products in the tank-truck markets.

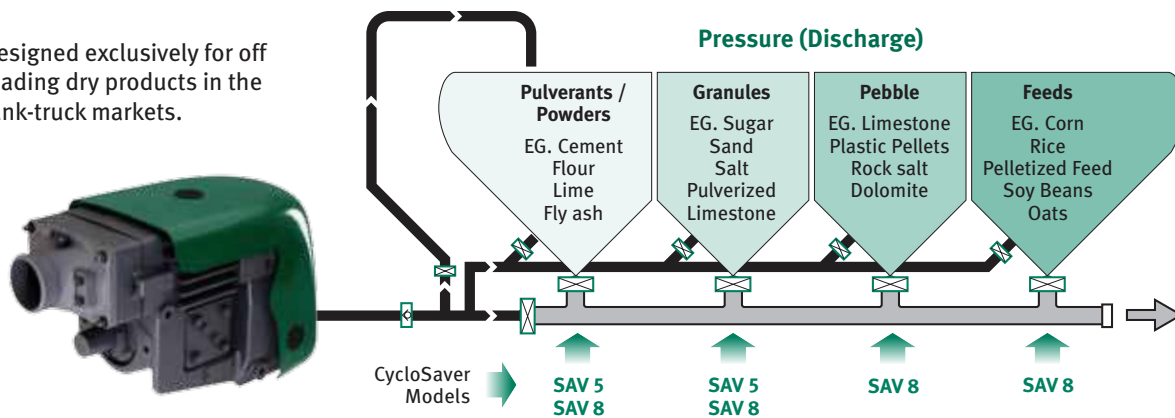

...It's the Future!

Unique CycloSaver Design Features

It's Innovative

The CycloSaver utilizes a proprietary rotary screw design to deliver unmatched performance.

Inlet Flange

A low profile inlet flange reduces the installation envelope.

Moulded Cover

The cover directs the cooling air over the machine and helps protect the compressor against the worst environmental conditions.

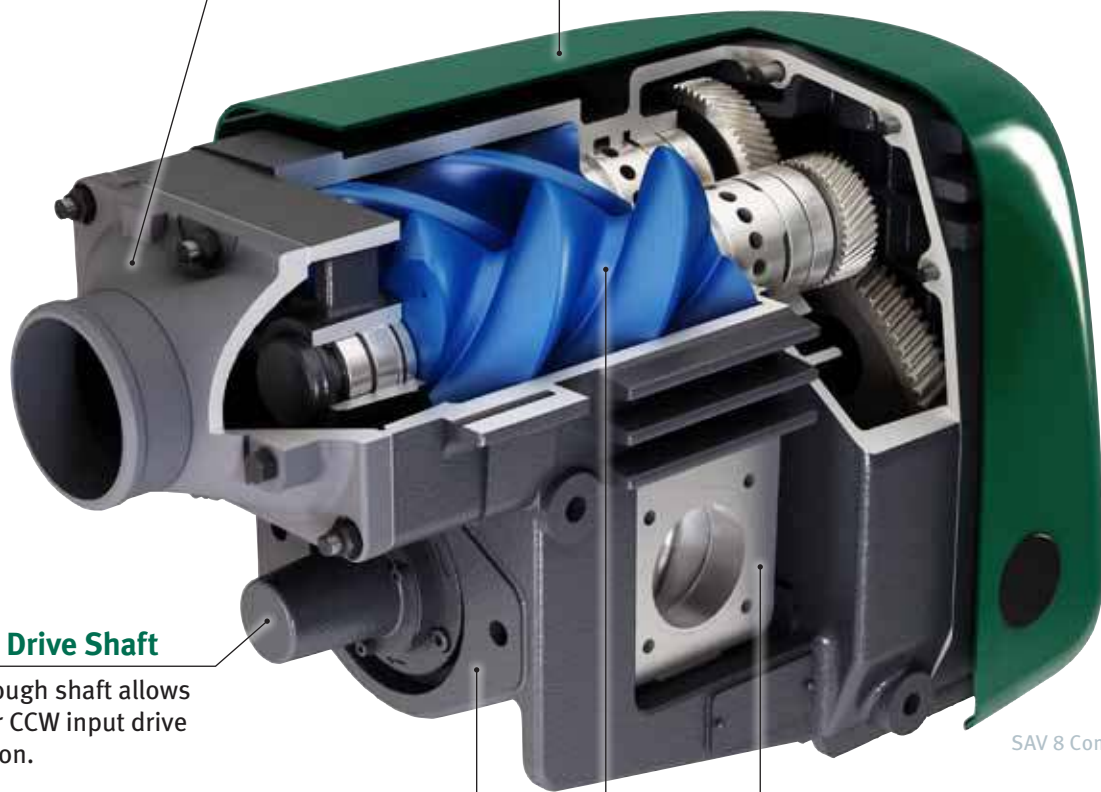

Dual Drive Shaft

A through shaft allows CW or CCW input drive rotation.

Connecting Flange

A 2 bolt connecting flange allows alternative drives to be used (eg. Hydraulic).

SAV 8 Compressor

Outlet Ports

An optional outlet flange on either side of the machine increases mounting flexibility.

Rotors

Coated helical screw rotors provide the maximum strength, performance and corrosion resistance.



It's Cool

- Lowest output temperatures of any comparable design
- Discharge air up to **80°F cooler** than other blowers
- Protects product integrity
- Reduces need for expensive and heavy auxiliary coolers
- Prolongs component life, lowering the total operating cost of your trailer

It's Quiet

- The CycloSaver is 10–12 dBA quieter than straight lobe blowers
- Helical screw-style rotors add to the longevity of your trailer by reducing the stress caused by pulsating bi-lobe blowers
- Decreases need for operator hearing protection
- Reduces need for additional sound abatement measures



“It (the CycloSaver) is much quieter than other blowers.”

—Operator, A National Trucking Company



Performance, Parts, Accessories & Service

It's Powerful

Capable of delivering up to 36 psi continuous pressure.

CycloSaver SAV5 Delivery

RPM	PSIG	0.0	7.3	14.5	22	29	36
1000	CFM	254	241	230	218	207	197
1200	CFM	303	292	281	271	262	250
1400	CFM	360	349	337	328	317	304
1600	CFM	421	406	391	379	368	357

CycloSaver SAV8 Delivery

RPM	PSIG	0.0	7.3	14.5	22	29	32
1000	CFM	347	334	323	312	299	294
1200	CFM	424	412	400	388	377	365
1400	CFM	496	486	477	468	456	452
1600	CFM	577	567	556	544	534	530
1800	CFM	655	642	631	619	607	603

Actual performance may vary based on system design, environment, and maintenance.

It's Compact

Easy installation.

Dimensions

Dimension (in)	A	B	C
SAV5	15.39	12.8	20.85
SAV8	15.39	12.8	25.26

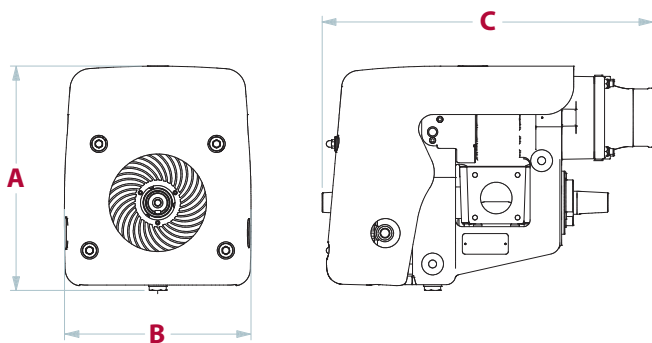

CycloSaver compact installation



“All parts are NOT created equal.”

All genuine Gardner Denver parts are factory engineered to meet the exact specifications of our machines. Only the highest quality components designed explicitly for our equipment are used. This provides the reliability to allow you to do your job with confidence.

Truck Blower Overhaul Kits

Gardner Denver certified kits use only factory-specified, original parts insuring “like-new” performance.

GD Inlet Filters

- Designed to withstand the heavy punishment of over-the-road operation
- Available in carbon-steel and stainless-steel



Standard Duty Filter



Stainless Steel Filter

Relief Valves

- Discharge fittings available in 2" line size
- Discharge check valves available
- Kits include: check valve, relief valve and camlock complete with dust cap



Relief Valve



Check Valve

Genuine GD Lubricants

Gardner Denver synthetic lubricants are formulated specifically to maximize machine performance and longevity.

Service Commitment

- Gardner Denver is proud to have a vast network of factory-trained and certified distributors.
- This provides 24/7 local service support and a level of expertise that is unmatched and offers you peace of mind.





Gardner Denver®



www.GardnerDenverProducts.com mobilesolutions@gardnerdenver.com

Gardner Denver, Inc. 1800 Gardner Expressway, Quincy, IL 62305
Telephone: (800) 682-9868 FAX: (217) 221-8780

©2011 Gardner Denver, Inc. Printed in U.S.A. GDT-CSAV-FAM 2nd 5/11



Member



Please recycle after use.