

GD150 Oil Free Compressor



The GD150 is a high flow, oil free, radial vane compressor for pressure off-loading of bulk liquids. The most modern materials and manufacturing methods make the GD150 compressor the most reliable and durable vane compressor available.

Features

- 100% oil free air for clean product unloading
- Corrosion resistant, stainless steel rotor will not corrode or de-plate like coated rotors
- Steel shafts for durability and strength
- Viton® seals
- High temperature blades
- Lightweight and compact with anodized aluminium body and side plates
- Double ended shaft for clockwise or counter clockwise drive
- Hydraulic drive mounting trunks available for direct coupling of hydraulic motors

GD150 Oil Free Compressor

- Pressure to 36 psig
- Flow rate to 75 cfm

GD
GARDNER DENVER™

Experience Proven Results™

GD150 Oil Free Compressor

Dimensions

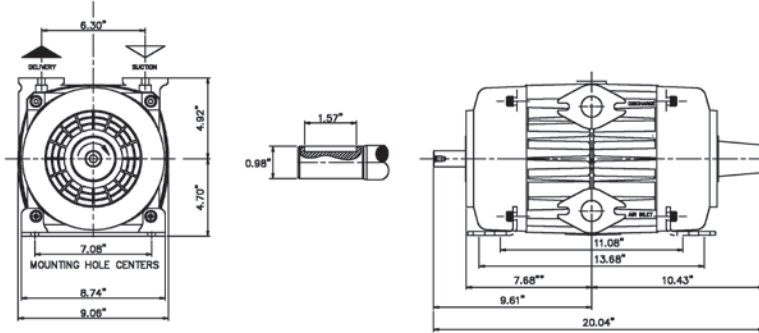

Accessories

The standard accessories supplied with the GD150 are:

- 1½" brass check valve
- Pressure relief valve 30 psi
- Detachable mounting feet
- Specially designed aluminum air filter
- 1½" NPTF port flanges

Options include:

- 1" stainless steel check valve
- Pressure relief valve 36 psi
- Drive flange
- 3 way ball valve
- Stainless steel mounting brackets

Performance

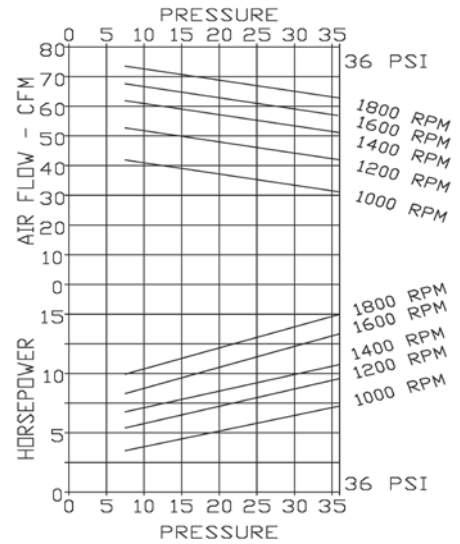

Gardner Denver®

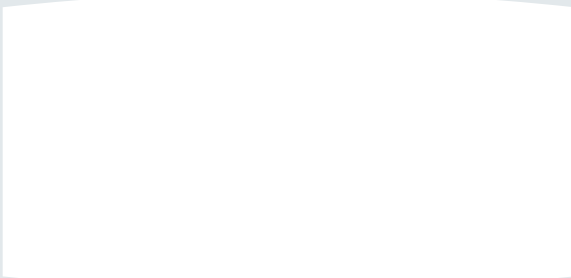

www.GardnerDenverProducts.com mobilesolutions@gardnerdenver.com

Gardner Denver, Inc. 1800 Gardner Expressway, Quincy, IL 62305
Telephone: (800) 682-9868 FAX: (217) 221-8780

©2009 Gardner Denver, Inc. Printed in U.S.A. GDT-GD150 1st 10/09

Supersedes GDD-2-114



Please recycle after use.



Member

